

# FM120

**CommercialIce**  
AUSTRALIA

- 120kg production 60kg storage



## SPECIFICATION

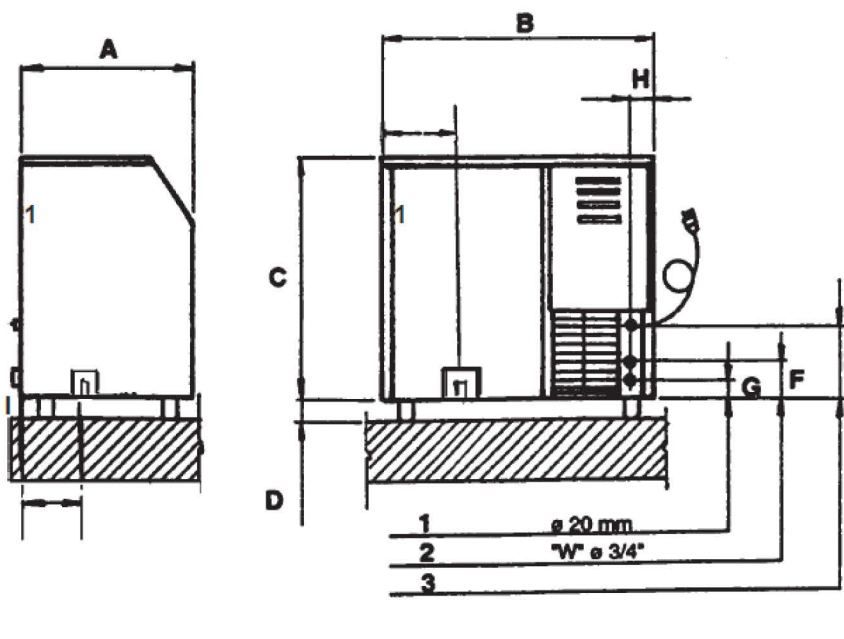

## DIMENSIONS

Width 920 mm  
Depth 590 mm  
Height 785 / 915 mm with legs

## PLUMBING CONNECTIONS

(E) 10 amp 1 metre power lead 285 mm  
(G) 20mm Water Outlet Gravity 58 mm  
(F) 3/4" Water Inlet 70 mm